



INTERNATIONAL APPLICATION PUBLISHED UNDER THE PATENT COOPERATION TREATY (PCT)

<p>(51) International Patent Classification ⁷ : H01R 13/703, 13/533, 13/627</p>	<p>A1</p>	<p>(11) International Publication Number: WO 00/46884 (43) International Publication Date: 10 August 2000 (10.08.00)</p>
---	------------------	---

(21) International Application Number: PCT/GB00/00312
 (22) International Filing Date: 4 February 2000 (04.02.00)
 (30) Priority Data: 9902467.1 5 February 1999 (05.02.99) GB
 (71) Applicant (for all designated States except US): ROTA ENGINEERING LIMITED [GB/GB]; Wellington Street, Bury, Lancashire BL8 2BD (GB).
 (72) Inventors; and
 (75) Inventors/Applicants (for US only): FAWCETT, Michael, J. [GB/GB]; 17 Seefield Road, Bury, Lancashire BL9 6NZ (GB). RYDE, Peter, Eric [GB/GB]; Langlands, Skipton Road, Gisburn, Clitheroe, Lancashire BB7 4HP (GB).
 (74) Agent: ALLMAN, Peter, John; Marks & Clerk, Sussex House, 83-85 Mosley Street, Manchester M2 3LG (GB).

(81) Designated States: AE, AL, AM, AT, AU, AZ, BA, BB, BG, BR, BY, CA, CH, CN, CR, CU, CZ, DE, DK, DM, EE, ES, FI, GB, GD, GE, GH, GM, HR, HU, ID, IL, IN, IS, JP, KE, KG, KP, KR, KZ, LC, LK, LR, LS, LT, LU, LV, MA, MD, MG, MK, MN, MW, MX, NO, NZ, PL, PT, RO, RU, SD, SE, SG, SI, SK, SL, TJ, TM, TR, TT, TZ, UA, UG, US, UZ, VN, YU, ZA, ZW, ARIPO patent (GH, GM, KE, LS, MW, SD, SL, SZ, TZ, UG, ZW), Eurasian patent (AM, AZ, BY, KG, KZ, MD, RU, TJ, TM), European patent (AT, BE, CH, CY, DE, DK, ES, FI, FR, GB, GR, IE, IT, LU, MC, NL, PT, SE), OAPI patent (BF, BJ, CF, CG, CI, CM, GA, GN, GW, ML, MR, NE, SN, TD, TG).

Published
 With international search report.

(54) Title: ISOLATING CONNECTOR

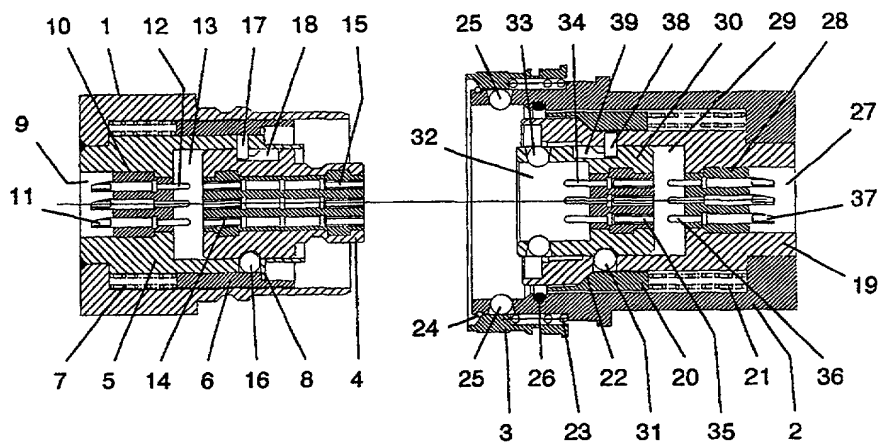

(57) Abstract

A connector for interconnecting or mutually isolating two circuits one of which is connected to a first connector element (1) and the other of which is connected to a second connector element (2) which is interengageable with the first. One of the connector elements supports a first contact (12) connected to a respective circuit and a displaceable contact holder (4) carrying interconnected second (14) and third (15) contacts. The contact holder is displaceable between a first position in which the first (12) and second (14) contacts are separated and a second position in which the first and second contacts are interconnected. The connector elements are formed such that on interengagement the contact holder is displaced from the first to the second position after the third contact is interconnected with a contact (34) of the other connector element (2). The arrangement is such that on disengagement of the connector elements (1, 2) the contact holder is displaced from the second to the first position. The contacts are arranged such that on disengagement the first and second contacts separate before the third contact is separated from the other connector element and such that when separated the first and second contacts are located within a closed chamber defined within the connector element in which the contact holder is supported.